

**VALVOLA A SFERA – MONOBLOCCO – PASSAGGIO RIDOTTO –
BRONZE - NI/AL BRONZE – FF – Serie 800 p.s.i.**

**BALL VALVE – 1 PIECE – REDUCED BORE - BRONZE - NI/AL BRONZE – FF – Series 800
p.s.i.**

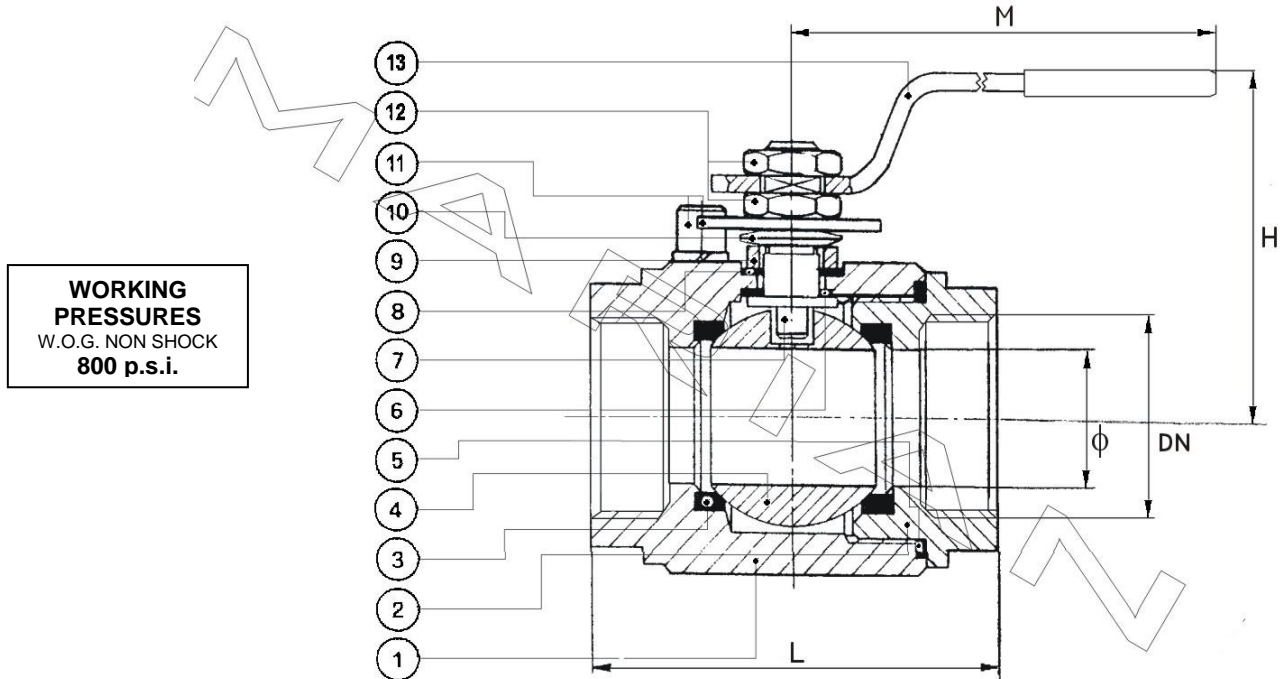

CONFORM TO: API STD 6FA / ISO 17292
FIRE SAFE DESIGN API 607 / BS 6755
MSS SP-110

OPTIONAL MATERIALS: CB 333G
ASTM B62 C83600

OPTIONAL TRIM MATERIALS: BALL/STEM AISI 316

	DESCRIZIONE	DESCRIPTION	BZ	AL / BZ	AL / BZ - MONEL
1	CORPO	BODY	ASTM B62 C83600	ASTM B148 C95500	ASTM B148 C95500
2	MANICOTTO	END PLUG	ASTM B62 C83600	ASTM B148 C95500	ASTM B148 C95500
3	SEGGIO	SEAT	P.T.F.E.	P.T.F.E.	P.T.F.E.
4	SFERA	BALL	ASTM B148 C95500	ASTM B148 C95500	MONEL K500
5	GUARNIZIONE	BODY SEAL	VITON	VITON	VITON
6	SEDE ASTA	STEM SEAT	GRAPHITE TEFLONED	GRAPHITE TEFLONED	GRAPHITE TEFLONED
7	ASTA	STEM	ASTM B150 C63000	ASTM B150 C63000	MONEL K500
8	GUARNIZIONE	GASKET	GRAPHITE TEFLONED	GRAPHITE TEFLONED	GRAPHITE TEFLONED
9	PREMISTOPPA	THRUST WASHER	ASTM A182 F316	ASTM A182 F316	ASTM A182 F316
10	MOLLE A TAZZA	SPRING DISCS	ASTM A182 F316	ASTM A182 F316	ASTM A182 F316
11	FERMO	STOP	ASTM A193 B7 ZINC. PL.	ASTM A182 F316	ASTM A182 F316
12	DADI	NUTS	ASTM A194 2H ZINC. PL.	ASTM A194 GR.8	ASTM A194 GR.8
13	LEVA	LEVER	CARBON STEEL	ASTM A182 F316	ASTM A182 F316

**THREADING: NPT (ANSI B1.20.1) or BSP (ISO 228/1)
SOLDER ENDS: SW (ANSI B16.11)**

DN	1/4"	3/8"	1/2"	3/4"	1"	1 1/4"	1 1/2"	2"	2 1/2"	3"	4"
Ø	10	10	10	15	20	25	30	38	48	65	73
L	67	67	67	75	90	105	120	135	155	190	205
M	153	153	153	153	186	186	233	233	280	358	380
H	65	65	65	70	77	95	100	105	115	162	145
Kg	0.60	0.60	0.55	0.90	1.50	2.00	3.20	4.50	5.00	14.00	17.50