

**VALVOLA A SFERA - PASSAGGIO TOTALE - OTTONE - SFERA INOX - FF - PN 40**  
**BALL VALVE - FULL BORE - BRASS - INOX BALL - FF - 250 LBS**

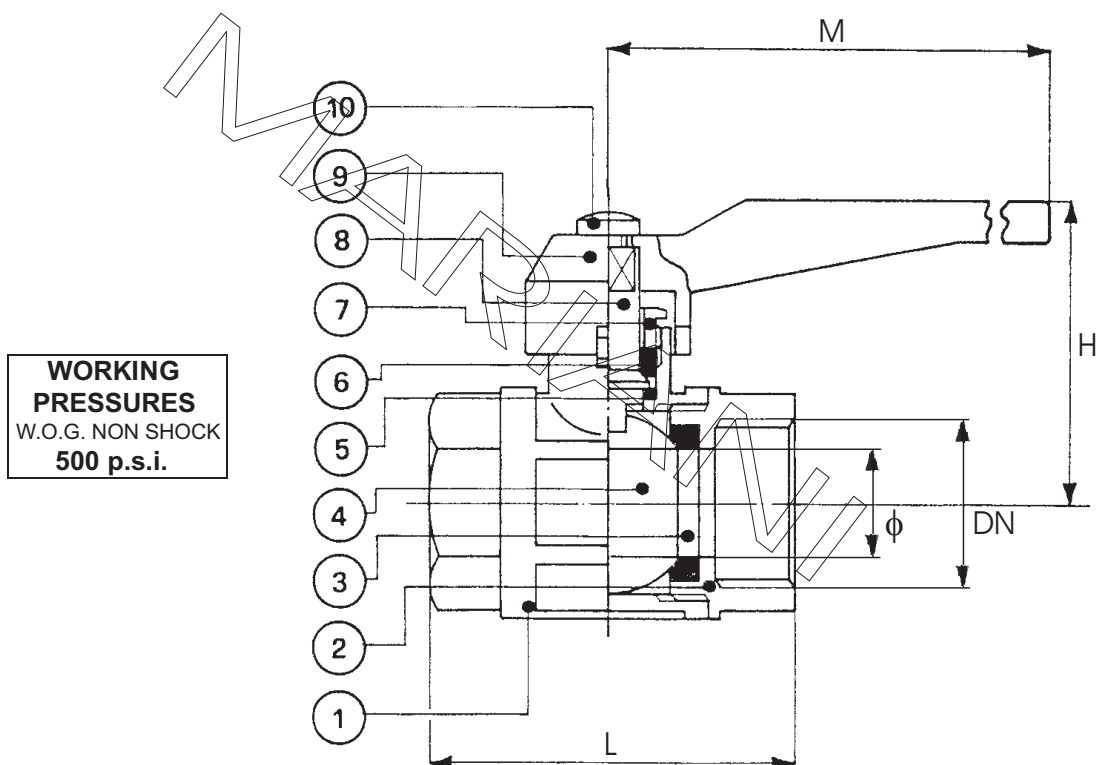

**WORKING PRESSURES**  
W.O.G. NON SHOCK  
**500 p.s.i.**

CONFORM TO: MSS SP 110

#BRASS ASTM B283=CuZn40Pb2 (UNI 5705/65)

OPTIONAL FEATURES: 1)EXTENDED WRENCH

	DESCRIZIONE	DESCRIPTION	MATERIAL
1	CORPO	BODY	BRASS ASTM B283 - CHROME PLATED#
2	MANICOTTO	END PLUG	BRASS ASTM B283 - CHROME PLATED
3	SEGGIO	SEAT	P.T.F.E.
4	SFERA	BALL	ASTM A182 F316
5	SEDE ASTA	STEM SEAT	P.T.F.E.
6	GUARNIZIONE	GASKET	P.T.F.E.
7	PREMISTOPPA	THRUST WASHER	BRASS ASTM B16
8	ASTA	STEM	BRASS ASTM B16
9	LEVA	LEVER	LAQUERED STEEL
10	VITE	LEVER SCREW	ZINC PLATED STEEL

**THREADING: GAS (ISO 7/1 Rp) FEMALE PARALLEL**

DN	1/4"	3/8"	1/2"	3/4"	1"	1 1/4"	1 1/2"	2"	2 1/2"	3"	4"
φ	10	10	15	20	25	32	39	48	64	78	100
L	46	46	56	66	75	85	97	109	141	159	190
M	92	92	92	92	117	150	150	150	240	240	320
H	48	48	50	58	65	80	87	97	125	140	160
Kg	0.200	0.180	0.250	0.350	0.550	1.050	1.500	2.300	4.900	7.300	9.300