

**VALVOLA A GLOBO – UNION BONNET – ASTA SALIENTE – NI/AL BRONZE – S.300**

**GLOBE VALVE - UNION BONNET - RISING STEM – NI/AL BRONZE – S.300**

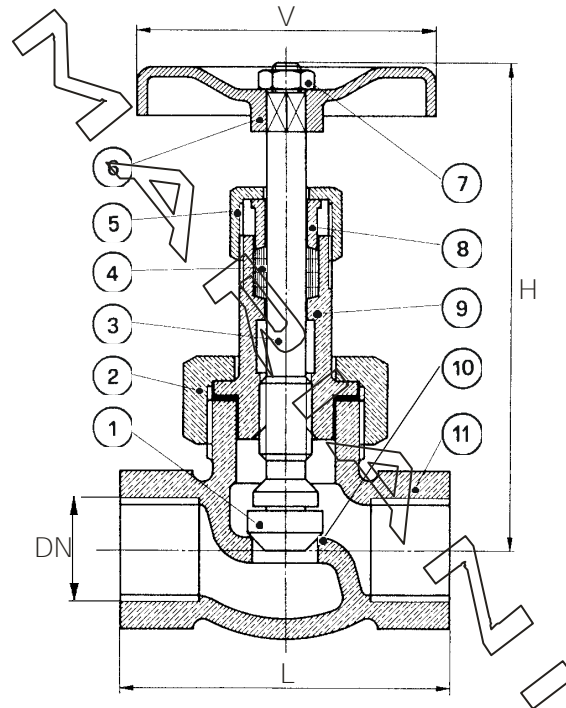

**CONFORM TO: BS 5154  
MSS SP 80  
BACKSEAT**

**OPTIONAL MATERIAL: BS 1400 AB2  
CB333G**

	DESCRIZIONE	DESCRIPTION	AL/BZ (Aluminium/Bronze)	AL/BZ -MONEL
1	OTTURATORE	DISC	ASTM B150 C63000	MONEL K500
2	CALOTTA	UNION-NUT	ASTM B62 C83600	ASTM B62 C83600
3	ASTA	STEM	ASTM B150 C63000	MONEL K500
4	BADERNA	STEM PACKING	PTFE	PTFE
5	DADO PREMISTOPPA	GLAND NUT	ASTM B62 C83600	ASTM B62 C83600
6	VOLANTINO	HANDWHEEL	CARBON STEEL	CARBON STEEL
7	DADO	NUT	ZINC PLATED STEEL	ZINC PLATED STEEL
8	PREMISTOPPA	THRUST WASHER	ASTM B148 C95800	ASTM B148 C95800
9	VITONE	BONNET	ASTM B148 C95800	ASTM B148 C95800
10	SEDE	SEAT	ASTM B148 C95800	MONEL K500
11	CORPO	BODY	ASTM B148 C95800	ASTM B148 C95800

**THREADING: NPT (ANSI B1.20.1) or BSP (ISO 228/1)**

DN	1/2"	3/4"	1"	1"1/4	1"1/2	2"	2"1/2	3"	4"
L	60	81	100	107	107	126	140	159	205
H (OPEN)	114	135	153	185	186	216	260	277	327
V	60	70	70	80	90	100	110	125	140
Kg	0.520	0.830	1.090	2.500	2.500	3.550	5.300	7.150	12.800