

1065

VALVOLA A SPILLO - VD -
ACCIAIO C./INOX - S.3000

NEEDLE VALVE - STRAIGHT WAY -
CARBON/STAINLESS ST. - S.3000

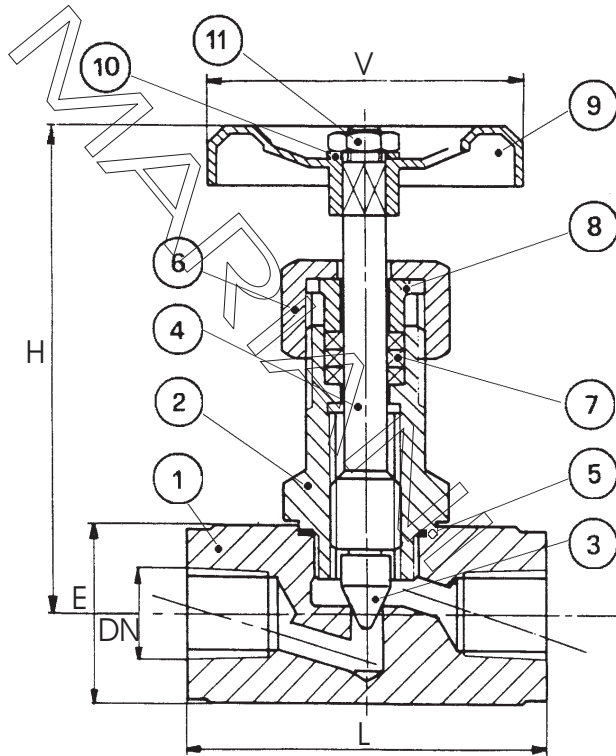

1066

VALVOLA A SPILLO - AR -
ACCIAIO C./INOX - S.3000

NEEDLE VALVE - RIGHT ANGLE -
CARBON/STAINLESS ST. - S.3000

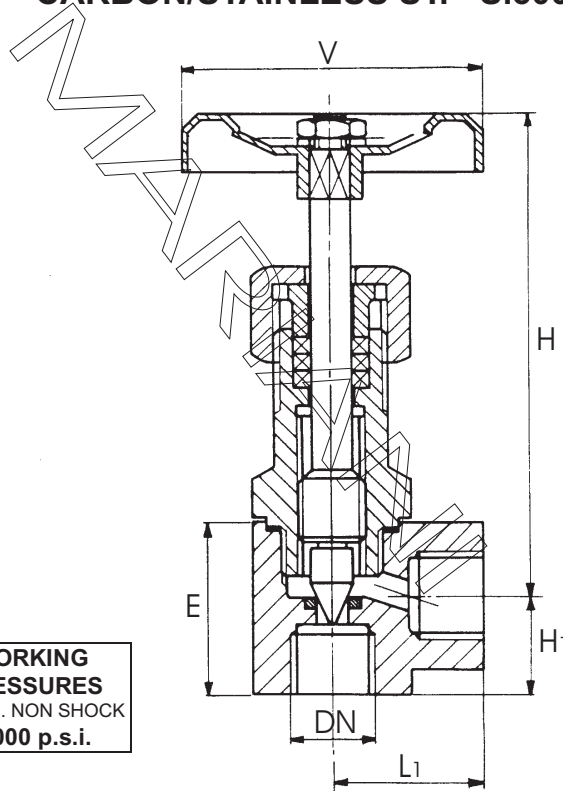

WORKING PRESSURES
W.O.G. NON SHOCK
3000 p.s.i.

OPTIONAL MATERIALS: 10)ASTM A350 LF2
11)MONEL K500

12)ASTM A494 CW12M1 (HASTELLOY C)
13)UNS-S 31803 (DUPLEX STAINLESS)

	DESCRIZIONE	DESCRIPTION	A (Carbon Steel)	INOX (Stainless Steel)
1	CORPO	BODY	ASTM A105	ASTM A182 F316
2	COPERCHIO	BONNET	ASTM A105	ASTM A182 F316
3	OTTURATORE	NEEDLE	ASTM A182 F6	ASTM A182 F316
4	ASTA	STEM	ASTM A182 F6	ASTM A182 F316
5	GUARNIZIONE	GASKET	GRAPHITE TEFLONED	GRAPHITE TEFLONED
6	DADO PREMISTOPPA	GLAND NUT	ASTM A105	ASTM A105
7	BADERNA	STEM PACKING	GRAPHITE TEFLONED	GRAPHITE TEFLONED
8	PREMISTOPPA	PACKING GLAND	ASTM A105	ASTM A182 F316
9	VOLANTINO	HANDWHEEL	LAQUERED STEEL	LAQUERED STEEL
10	RONDELLA	WASHER	ASTM A105	ASTM A105
11	DADO - VOLANTINO	HANDWHEEL NUT	ZINC PLATED STEEL	ZINC PLATED STEEL

THREADING: NPT (ANSI B1.20.1) or GAS (ISO 7/1 Rp) FEMALE PARALLEL

SOLDER ENDS: SW (ANSI B16.11)

DN	1/4"	3/8"	1/2"	3/4"	1"	1 1/4"	1 1/2"	2"
L	60	60	70	78	90	100	130	140
L1	30	30	35	40	45	60	70	70
H	100	100	100	115	145	150	160	170
H1	18	18	20	23	30	35	40	40
E	30	30	35	40	45	60	70	80
V	70	70	70	80	90	100	125	150
Kg1065	0.550	0.550	0.750	1.100	2	2.500	3	3.500
Kg1066	0.500	0.500	0.700	1.050	1.900	2.350	2.800	3.250