

# 1055

**VALVOLA PORTAMANOMETRO  
C/VITE DI AZZERAMENTO -  
ACCIAIO C./INOX - S.3000**

**MANOMETER HOLDER COCK  
WITH INSTRUMENT ZERO SETTING -  
CARBON/STAINLESS ST. - S.3000**

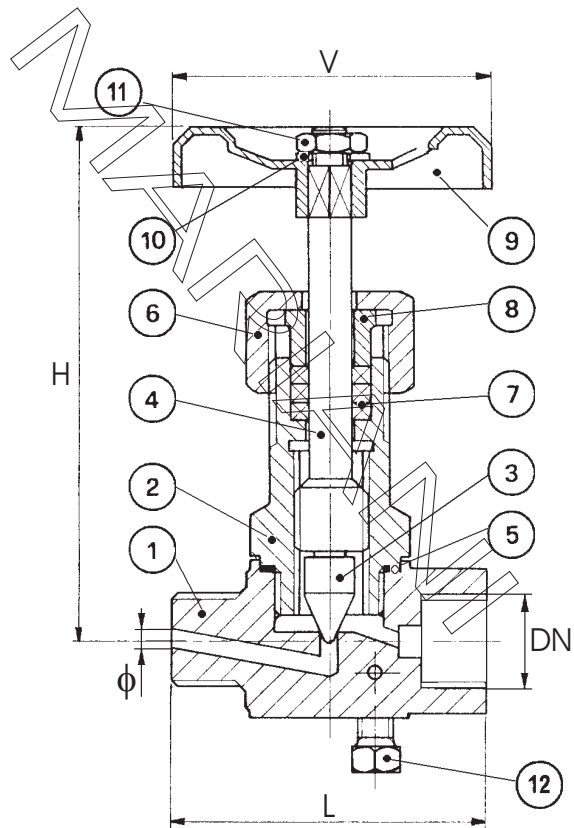

**WORKING  
PRESSURES**  
W.O.G. NON SHOCK  
3000 p.s.i.

# 1060

**VALVOLA PORTAMANOMETRO  
A TRE VIE C/VITE DI AZZERAMENTO  
E FLANGIA DI CONTROLLO -  
ACCIAIO C./INOX - S.3000**

**THREE WAYS MANOMETER HOLDER  
COCK WITH INSTRUMENT ZERO  
SETTING AND CONTROL FLANGE -  
CARBON/STAINLESS ST. - S.3000**

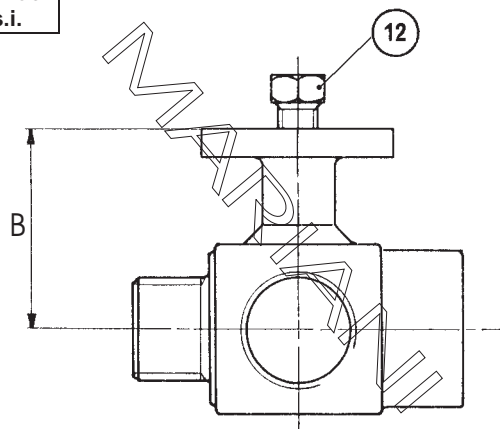

**OPTIONAL MATERIALS:** 10)ASTM A350 LF2  
11)MONEL K500  
12)ASTM A494 CW12M1 (HASTELLOY C)  
13)UNS-S 31803 (DUPLEX STAINLESS)

	DESCRIZIONE	DESCRIPTION	A (Carbon Steel)	INOX (Stainless Steel)
1	CORPO	BODY	ASTM A105	ASTM A182 F316
2	VITONE	BONNET	ASTM A105	ASTM A182 F316
3	OTTURATORE	NEEDLE	ASTM A182 F6	ASTM A182 F316
4	ASTA	STEM	ASTM A182 F6	ASTM A182 F316
5	GUARNIZIONE	GASKET	GRAPHITE TEFLONED	GRAPHITE TEFLONED
6	DADO PREMISTOPPA	SCREWED ENDS	ASTM A105	ASTM A182 F316
7	BADERNA	STEM PACKING	GRAPHITE TEFLONED	GRAPHITE TEFLONED
8	PREMISTOPPA	THRUST WASHER	ASTM A105	ASTM A182 F316
9	VOLANTINO	HANDWHEEL	LAQUERED STEEL	LAQUERED STEEL
10	RONDELLA	WASHER	ASTM A105 GR.II	ASTM A105 GR.II
11	DADO - VOLANTINO	HANDWHEEL NUT	ZINC PLATED STEEL	ZINC PLATED STEEL
12	VITE	SETTING SCREW	ZINC PLATED STEEL	ASTM A193 B8

**THREADING: GAS (ISO 7/1 Rp) or NPT (ANSI B1.20.1)**

DN	φ	L	H	B	V	Kg
1/4"	3	61	100	35	70	0.600
3/8"	3	61	100	35	70	0.650
1/2"	5	70	100	40	70	0.765